

Polished chrome plated flush valve, diaphragm type, 1.6 gallons per flush, externally adjustable for water conservation, with 1" capped screwdriver angle stop with back-check, renewable main valve seat, metal "Rubberflex" oscillating handle, "Turn-to-Silence" equipment, with "Kwikfit" threaded union tailpiece, offset vacuum breaker, with 977 bedpan diverter valve, wall support, wall flange, spud nut and spud flange for 1½" top spud.

Variations

- C - 3" Oscillating disc
- E - One wall bumper (for seat with cover or closed front seat without cover)
- F - Two wall bumpers (for open front seat without cover)
- L - Handle or push-button on front of valve
- T6 - Heavy cast wall flange with allen head set screw
- T7 - Nickel-silver handle, push-button, or oscillating disc, as applicable
- T8 - Sweat inlet stop
- T36 - Solid ring wall support for flush connection
- T42 - Sweat adapter kit for stop
- T46 - Split ring wall support for flush connection

Remark

* For use with 1.6 gallon low consumption water closet

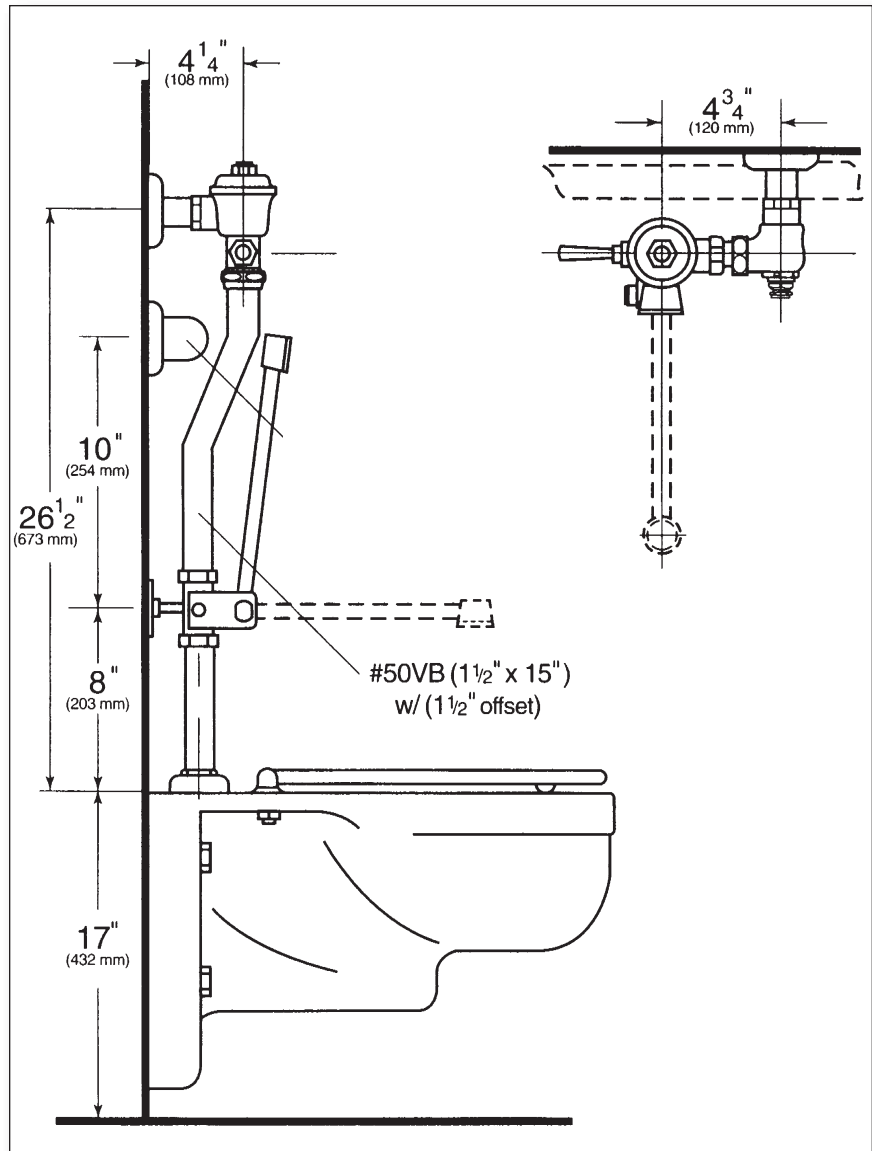

Note: In some localities local code requires that the Spray Arm Head be 6" below the critical level line on the vacuum breaker.



P.O. Box 411 · Charlottesville · VA · 22902 · USA
Phone: (434) 296-0166 · Fax (434) 977-3596
Email: info@delanyproducts.com
Web: www.delanyproducts.com
©2009