

**C**oncealed rough brass flush valve, diaphragm type, externally adjustable for water conservation, with 1" wheel handle angle stop with back-check, renewable main valve seat, equipped with push-button hydro-flush actuator through wall, wall flange, "Turn-to-Silence" equipment, with "Kwikfit" threaded union tail-piece, body casting for roughing left or right vacuum breaker, elbow flush connection for 1½" concealed back spud. All exposed parts polished chrome. Includes 194 Sweat Adaptor.

**Variations**

- 3 - Water saver equipment
- A - Screwdriver operated stop
- C - 3" Oscillating disc
- M - 1¼" Female I.P. union outlet
- T7 - Nickel-silver handle, push-button, or oscillating disc, as applicable
- T8 - Sweat inlet stop
- T37 - Non-syphon bypass
- T42 - Sweat adaptor kit for stop
- Y - 1" Straight stop
- 
- 

**Remarks**

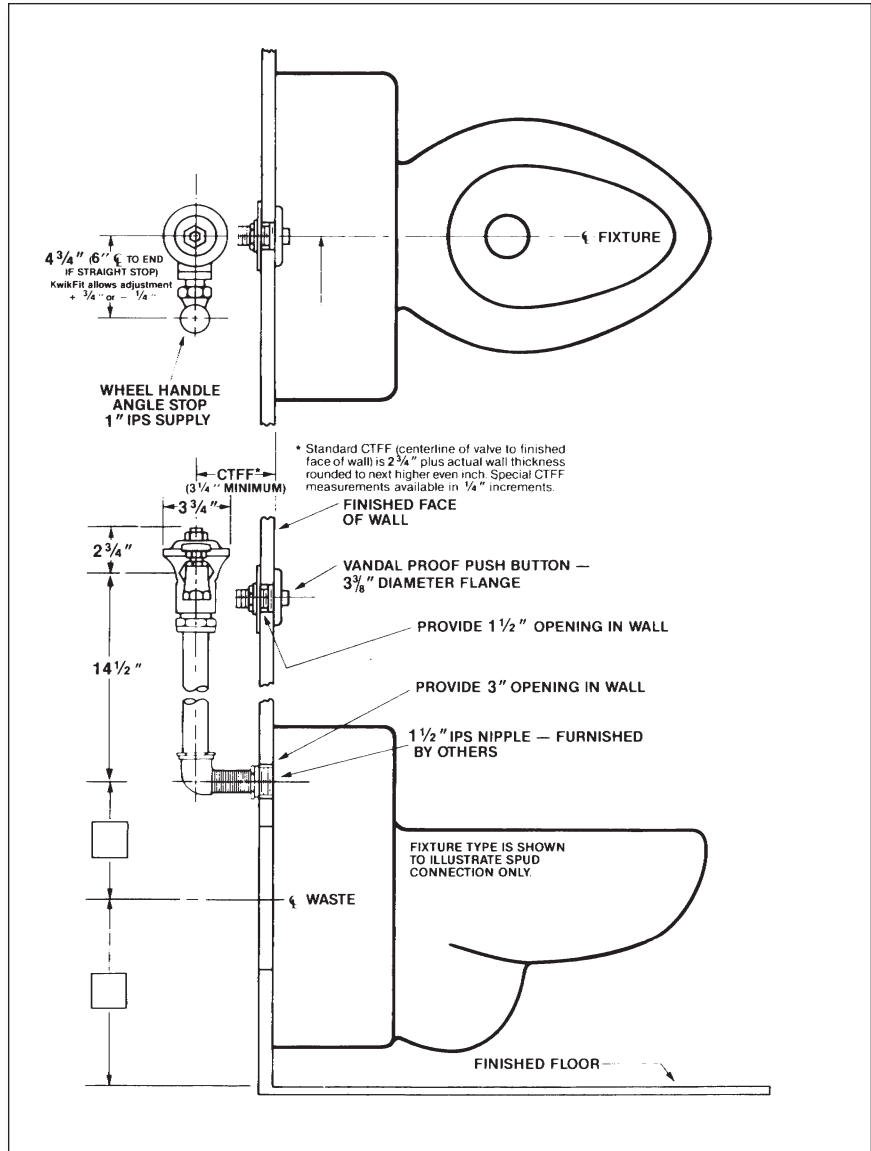

**Recommended For:** Penal or heavier duty installations where vandalism and abuse are common. No parts of valve can be removed from face of wall. Access to rear of wall for future service of valve and vacuum breaker must be provided.

