

1246-1.6

“L.C.” LOW CONSUMPTION
FLUSH VALVE (1.6 GALS. PER FLUSH)

Concealed rough brass flush valve, diaphragm type, 1.6 gallon per flush, externally adjustable for water conservation, with 1” wheel handle angle stop with back-check, renewable main valve seat, equipped with push-button hydro-flush actuator through wall, wall flange, “Turn-to-Silence” equipment, with “Kwikfit” threaded union tailpiece, vacuum breaker, elbow flush connection for 1½” exposed back spud, wall flange, spud nut and spud flange. All exposed parts polished chrome. Includes 194K Sweat Adaptor.

Variations

- 3 – Water saver equipment
- B – ½” Push-button
- C – 3” Oscillating disc
- E – One wall bumper (for seat with cover or closed front seat without cover)
- F – Two wall bumpers (for open front seat without cover)
- T6 – Heavy cast wall flange with allen head set screw
- T7 – Nickel-silver handle, push-button, or oscillating disc, as applicable
- T8 – Sweat inlet stop
- T42 – Sweat adapter kit for stop
- Y – 1” Straight stop

Remarks

* For use with 1.6 gallon low consumption water closet

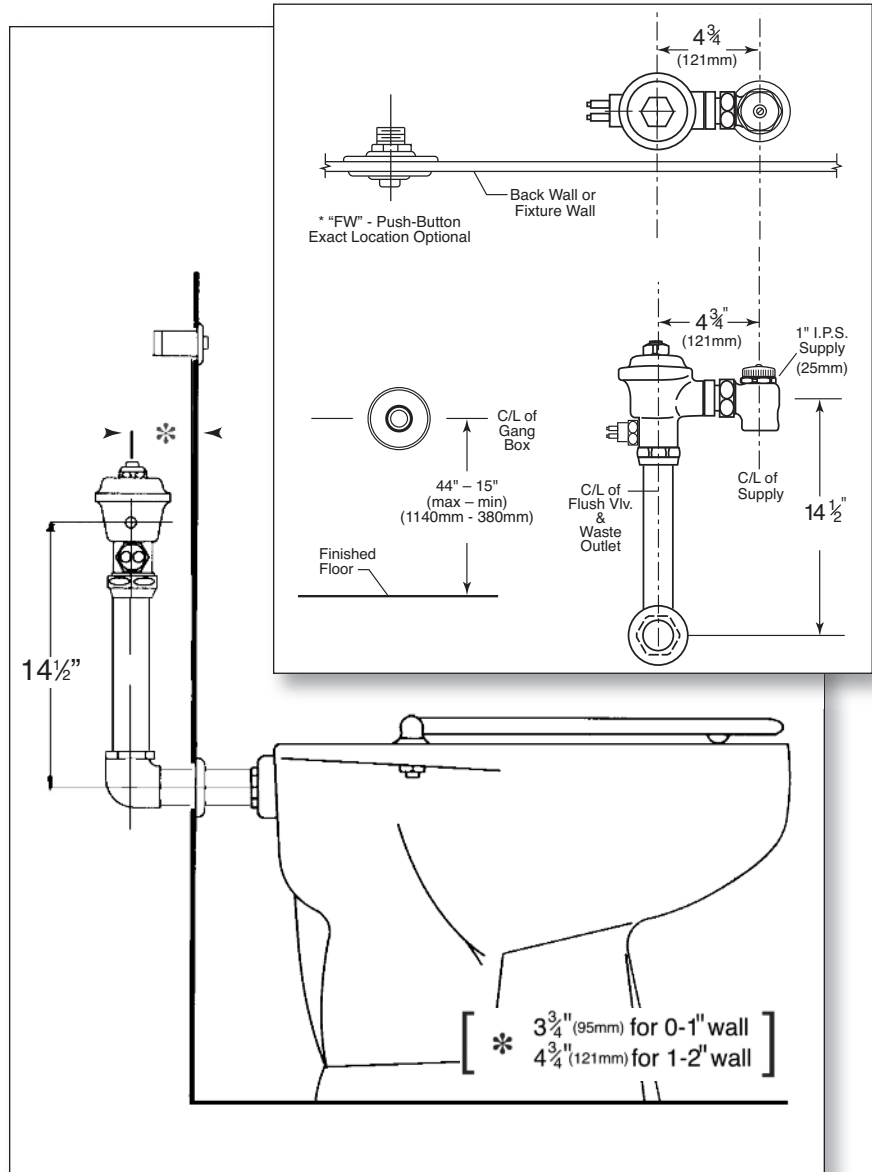

P.O. Box 411 · Charlottesville · VA · 22902 · USA
Phone: (434) 296-0166 · Fax (434) 977-3596
Email: info@delanyproducts.com
Web: www.delanyproducts.com
©2009