

537-1.6C

**"L.C." LOW CONSUMPTION
FLUSH VALVE (1.6 GALS. PER FLUSH)**

Concealed rough brass flush valve, diaphragm type, 1.6 gallons per flush, externally adjustable for water conservation, with 1" wheel handle angle stop with back-check, renewable main valve seat, 3" metal "Rubberflex" oscillating disc through wall, wall flange, "Turn-to-Silence" equipment, with "Kwikfit" threaded union tailpiece, vacuum breaker, elbow flush connection for 1/2" concealed back spud. All exposed parts polished chrome.

Variations

- A – Screwdriver operated stop
- B – 1/2" Push-button
- E – One wall bumper (for closed front seat without cover)
- F – Two wall bumpers (for open front seat without cover)
- O – Flush connection for 1/4" spud
- T28 – Oscillating handle
- T42 – Sweat adapter kit for stop
- Y – 1" Straight stop

Remarks

* *For use with 1.6 gallon low consumption water closet*

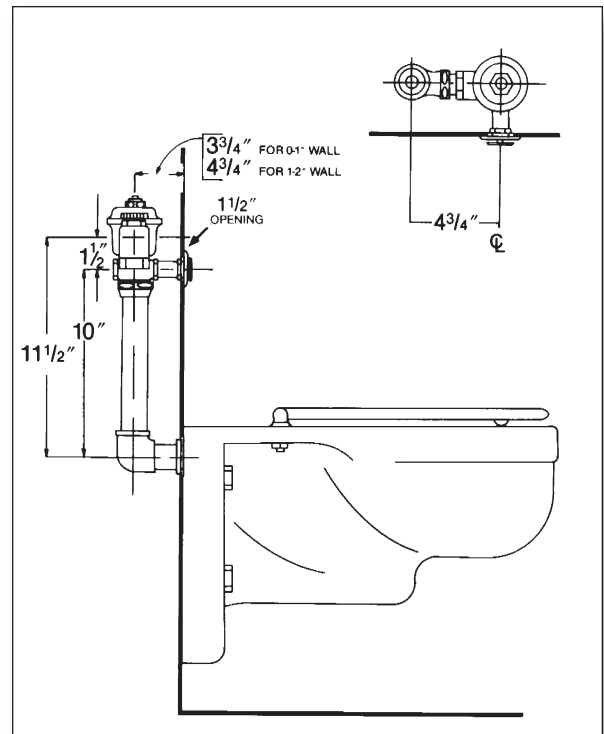

P.O. Box 411 · Charlottesville · VA · 22902 · USA
Phone: (434) 296-0166 · Fax (434) 977-3596
Email: info@delanyproducts.com
Web: www.delanyproducts.com
©2009