

1272-1.5

WATER SAVER URINAL FLUSH VALVE (1.5 GALS. PER FLUSH)

Concealed rough brass flush valve, diaphragm type, 1.5 gallons per flush, externally adjustable for water conservation, with 1" wheel handle angle stop with back-check, renewable main valve seat, equipped with push-button hydro-flush actuator through wall, wall flange, "Turn-to-Silence" equipment, with "Kwikfit" threaded union tailpiece, vacuum breaker, elbow flush connection for concealed back spud. All exposed parts polished chrome. Includes 194 Sweat Adaptor.

Variations

- A - Screwdriver operated stop
- H - Flush connection for 1½" spud
- T8 - Sweat inlet stop
- Y - 1" Straight stop

Remarks

* For use with 1.5 gallon water saver urinals

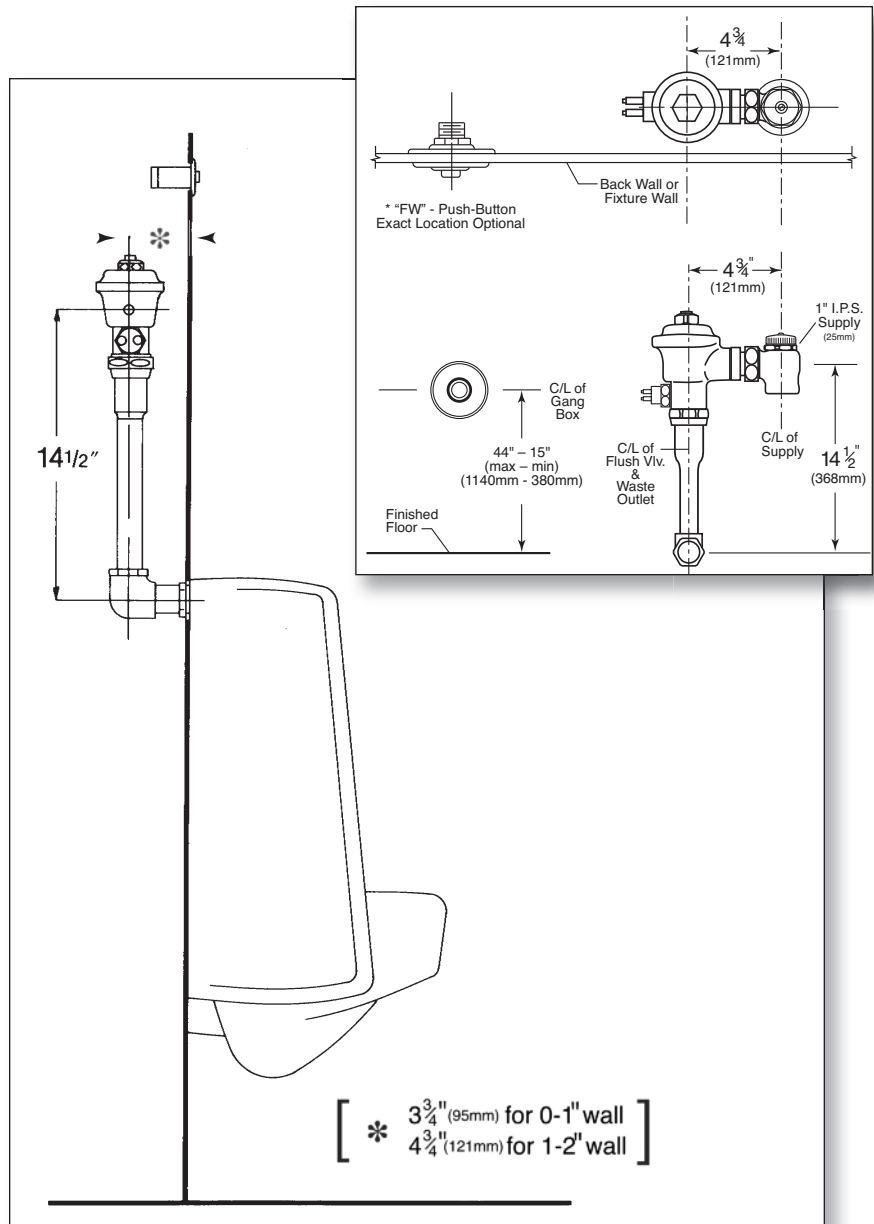

P.O. Box 411 · Charlottesville · VA · 22902 · USA
Phone: (434) 296-0166 · Fax (434) 977-3596
Email: info@delanyproducts.com
Web: www.delanyproducts.com
©2009