

572-1.5

WATER SAVER URINAL FLUSH VALVE
(1.5 GALS. PER FLUSH)

Concealed rough brass flush valve, diaphragm type, 1.5 gallons per flush, externally adjustable for water conservation, with 1" wheel handle angle stop with back-check, renewable main valve seat, metal "Rubberflex" oscillating handle through wall, wall flange, "Turn-to-Silence" equipment, with "Kwikfit" threaded union tailpiece, vacuum breaker, elbow flush connection for 1/4" concealed back spud. All exposed parts polished chrome.

Variations

- B - 1/2" Push button
- C - 3" Oscillating disc
- H - Flush connection for 1/2" spud
- T6 - Heavy cast wall flange with allen head set screw
- T7 - Nickel-silver handle, push button, or oscillating disc, as applicable
- T8 - Sweat inlet stop
- T42 - Sweat adapter kit for stop
- Y - 1" Straight stop

Remarks

* For use with 1.5 gallon water saver urinal

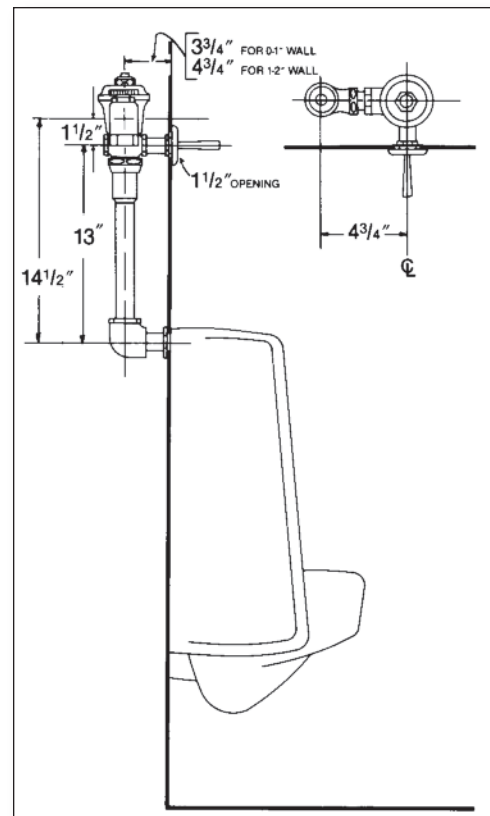

P.O. Box 411 · Charlottesville · VA · 22902 · USA
Phone: (434) 296-0166 · Fax (434) 977-3596
Email: info@delanyproducts.com
Web: www.delanyproducts.com
©2009