

410-1.6

**"L.C." LOW CONSUMPTION  
FLUSH VALVE (1.6 GALS. PER FLUSH)**

**P**olished chrome plated flush valve, diaphragm type, 1.6 gallons per flush, externally adjustable for water conservation, with 1" capped screwdriver angle stop with back-check, renewable main valve seat, metal "RubberFlex" oscillating handle, "Turn-to-Silence" equipment, with "Kwikfit" threaded union tailpiece, vacuum breaker, wall flange, spud nut and spud flange for 1½" top spud.

**Variations**

- C – 3" Oscillating disc
- E – One wall bumper (for seat with cover or closed front seat without cover)
- F – Two wall bumpers (for open front seat without cover)
- L – Handle or push-button on front of valve
- T6 – Heavy cast wall flange with allen head set screw
- T7 – Nickel-silver handle, push-button, or oscillating disc, as applicable
- T8 – Sweat inlet stop
- T36 – Solid ring wall support for flush connection
- T42 – Sweat adapter kit for stop
- T46 – Split ring wall support for flush connection

**Remarks**

\* *For use with 1.6 gallon low consumption water closet*

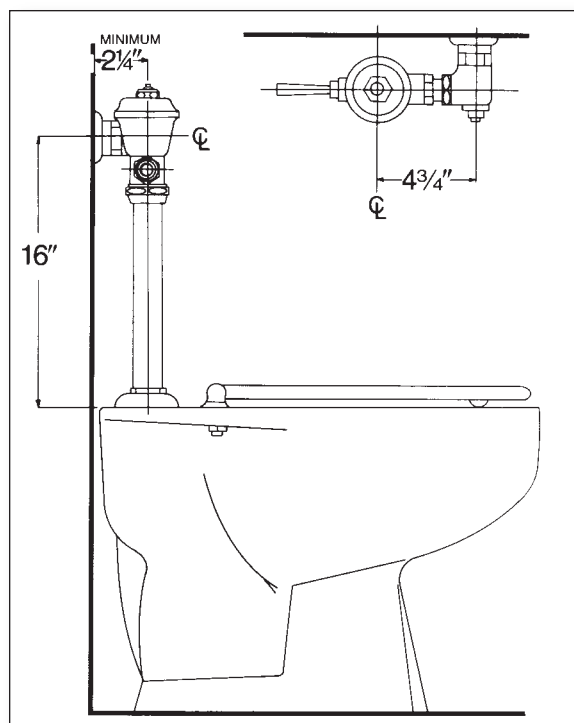

P.O. Box 411 · Charlottesville · VA · 22902 · USA  
Phone: (434) 296-0166 · Fax (434) 977-3596  
Email: info@delanyproducts.com  
Web: www.delanyproducts.com  
©2009