

1352-1.5

WATER SAVER URINAL FLUSH VALVE
(1.5 GALS. PER FLUSH)

Sensor operated polished chrome plated flush valve, diaphragm type, 1.5 gallons per flush, externally adjustable for water conservation, equipped with solenoid and sensor unit, with wall cover plate for electrical gang box with tamper-proof screws, with 1" capped screwdriver angle stop with back-check, renewable main valve seat, "Turn-to-Silence" equipment, with "Kwikfit" threaded union tailpiece, vacuum breaker, wall flange, spud nut and spud flange for 1/4" top spud. *UL Listed.*

Variations

- H - Flush connection for 1/2" spud
- R - Wheel handle operated stop
- T6 - Heavy cast wall flange with allen head set screw
- T42 - Sweat adapter kit for stop

Electrical Variations

___For: -24 Volts (requires transformer)

Sensor: -Input 24VAC
-Output 24 VAC

Solenoid: -24VAC 50/60 Hz

Transformer: -120VAC 50/60 Hz Primary
-24VAC 50/60 Hz Secondary

___For: -110 Volts

Sensor: -Input 120VAC
-Output 120 VAC

Solenoid: -120VAC / 60Hz (6.2 Watts)

Remarks

* *For use with 1.5 gallon water saver urinal*

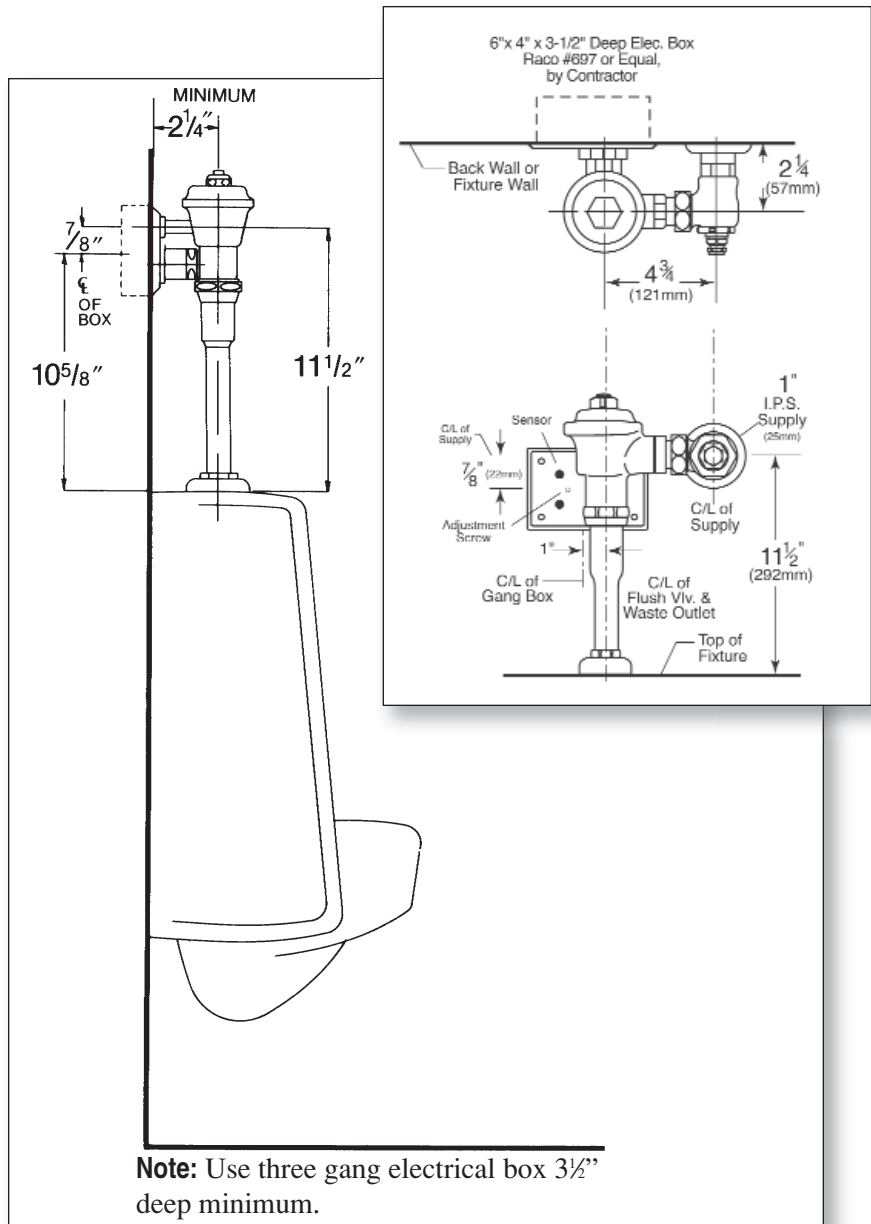

P.O. Box 411 · Charlottesville · VA · 22902 · USA
Phone: (434) 296-0166 · Fax (434) 977-3596
Email: info@delanyproducts.com
Web: www.delanyproducts.com
©2009