

Specifications

Sensor Control Circuit:	Solid State 6.0V DC Input
Timing Delay:	8 sec. Activation Delay
Sensor Range:	12"-40", Range Adjustable
Battery Type:	1 – Camera Style, Double Cell Six (6) Volts, Lithium Battery Ind. Stdrd. No. 2CR5
Battery Life:	5 Years (est 4,000 flushes/month)
Low Battery Indicator Light	Green Indicator light flashes when battery status is "poor"; approx. 5,000 flushes are left in the battery
Cleanser Flush:	A flush every 24 hours (Optional)
Cover Material:	ABS, Non-toxic Plastic UL Approved Fire Rating: UL-94-V
Water Pressure Range:	20-100 psi

Installation Drawings

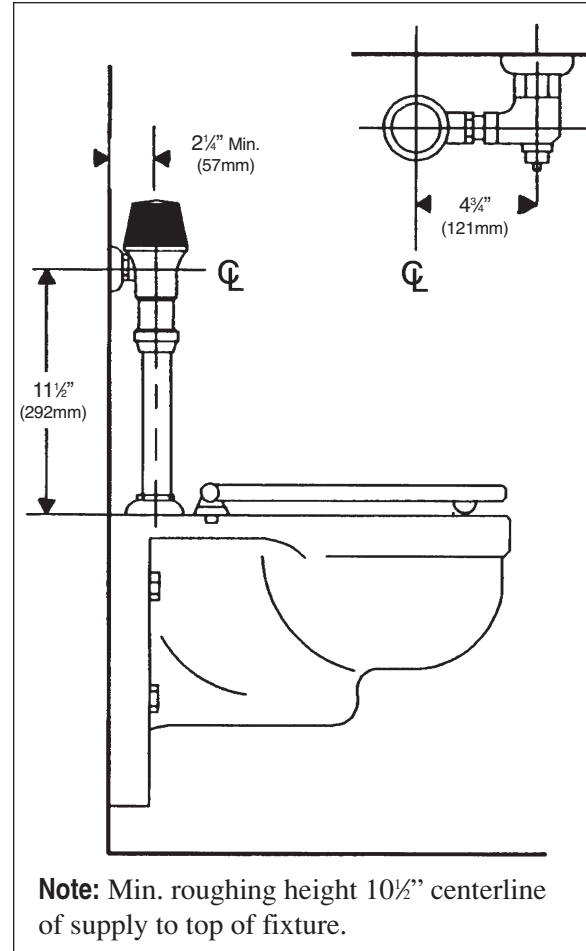

I 1402



P.O. Box 411 · Charlottesville · VA · 22902 · USA
 Phone: (434) 296-0166 · Fax (434) 977-3596
 Email: info@delanyproducts.com
 Web: www.delanyproducts.com
 ©2009