

“L.C.” LOW CONSUMPTION  
FLUSH VALVE (1.6 GALS. PER FLUSH)

**S**pecification: Concealed rough brass flush valve, diaphragm type, 1.6 gallons per flush, externally adjustable for water conservation, with 1” wheel handle angle stop with back-check, renewable main valve seat, metal “Rubberflex” push-button through wall, wall flange, “Turn-to-Silence” equipment, with “Kwikfit” threaded union tailpiece, twin body openings for roughing left or right, vacuum breaker, elbow flush connection for 1½” concealed back spud. All exposed parts polished chrome.

#### Variations

- A – Screwdriver operated stop
- C – 3” Oscillating disc
- M – 1¼” Female I.P. union outlet
- T7 – Nickel-silver handle, push-button, or oscillating disc, as applicable
- T8 – Sweat inlet stop
- T28 – Oscillating handle
- T37 – Non-syphon bypass
- T42 – Sweat adapter kit for stop
- T48 – Valve for use with an access box
- Y – 1” Straight stop

#### Remarks

\* For use with 1.6 gallon low consumption water closet

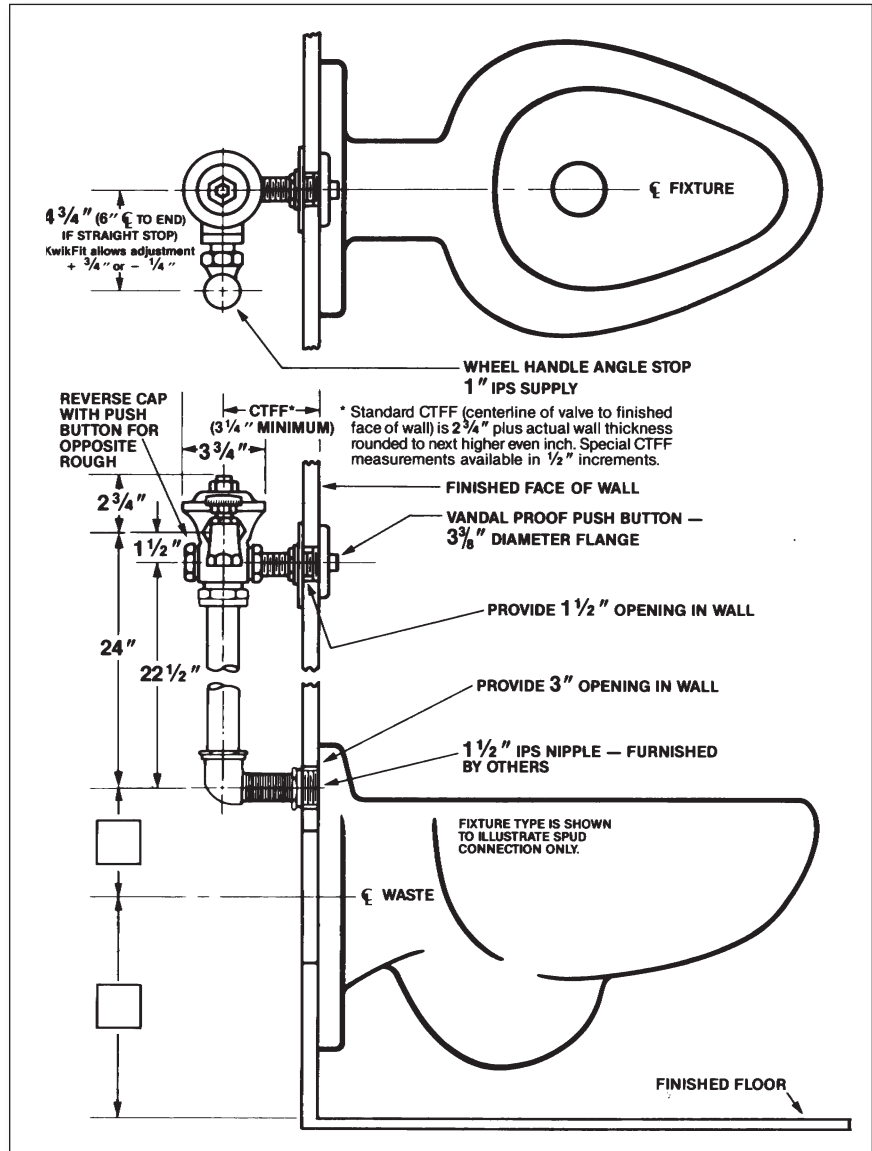

**Recommended For:** Penal or heavier duty installations where vandalism and abuse are common. No parts of valve can be removed from front face of wall. Access to rear of wall for future service of valve and vacuum breaker must be provided.



P.O. Box 411 · Charlottesville · VA · 22902 · USA  
Phone: (434) 296-0166 · Fax (434) 977-3596  
Email: info@delanyproducts.com  
Web: www.delanyproducts.com  
©2009