

# U451-0.125

HIGH EFFICIENCY URINAL FLUSH VALVE  
(0.125 gpf / 0.5 Lpf per Flush)

## Flushboy ULTRA

### Description

Exposed chrome plated flush valve for 0.75" top spud Urinals.

### Flush Cycle

0.125 gpf / 0.5 Lpf High Efficiency

### Specification

- Regulating screw for "True-in-the-Field" water conservation.
- ADA compliant metal "Rubberflex" oscillating handle.
- Renewable main valve seat.
- 1" vandle resistant capped screwdriver angle stop with back-check.
- Sweat adapter kit.
- SlipFit adjustable tailpiece.
- 3/4" x 9" vacuum breaker flush connection.
- Wall flange, spud nut and spud flange for 3/4" top spud.
- All rubber parts molded of chloramine resistant rubber.

### Variations

- AM - Antimicrobial Coated Handle
- SM - Side mounted battery powered sensor actuator
- T5 - Non-Hold-Open Feature
- T6 - Wall flange with allen set screw
- T36 - Solid ring wall support for flush connection
- T46 - Split ring wall support for flush connection
- TS - TruStop - Ball valve designed Control Stop
- VPS - Vandal Proof Control Stop with Key

Valve is certified to be in compliance to the applicable sections of ASSE 1037 and ANSI/ASME 112.19.2 WaterSense Listed and compliant when paired with a WaterSense compliant fixture.

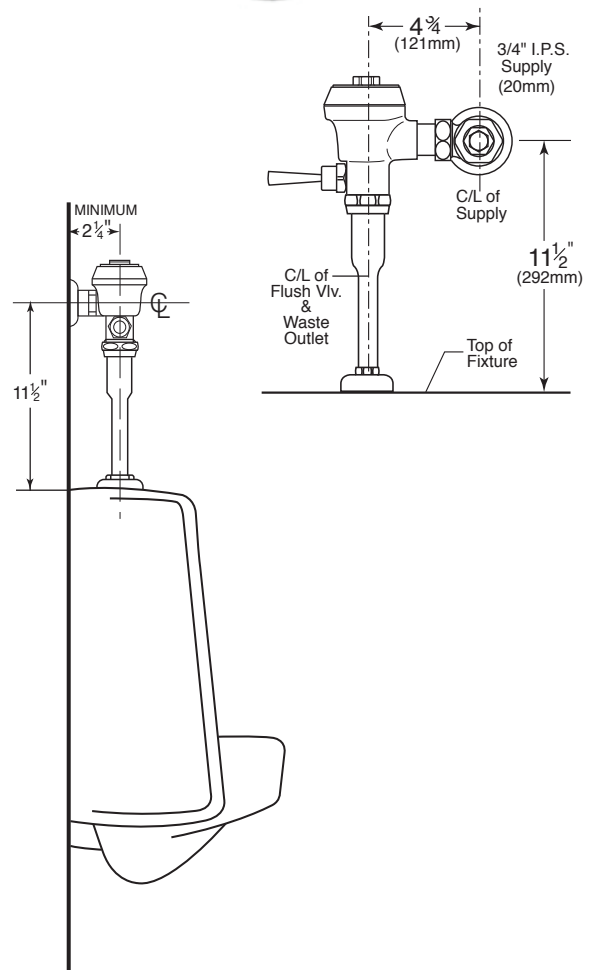

ASSE 1037

